

Water Level Detection Digital Sensor

BM62S3202-1

Characteristics

- Integrates MCU and air pressure sensor
- Measurement range 0~600mmH₂O, suitable for most washing machines
- Accuracy: ±1.5% F.S @0~70°C
- Resolution: 1mmH₂O
- 100% factory calibrated, with temperature compensation
- Digital water level output (mmH₂O)

Block Diagram

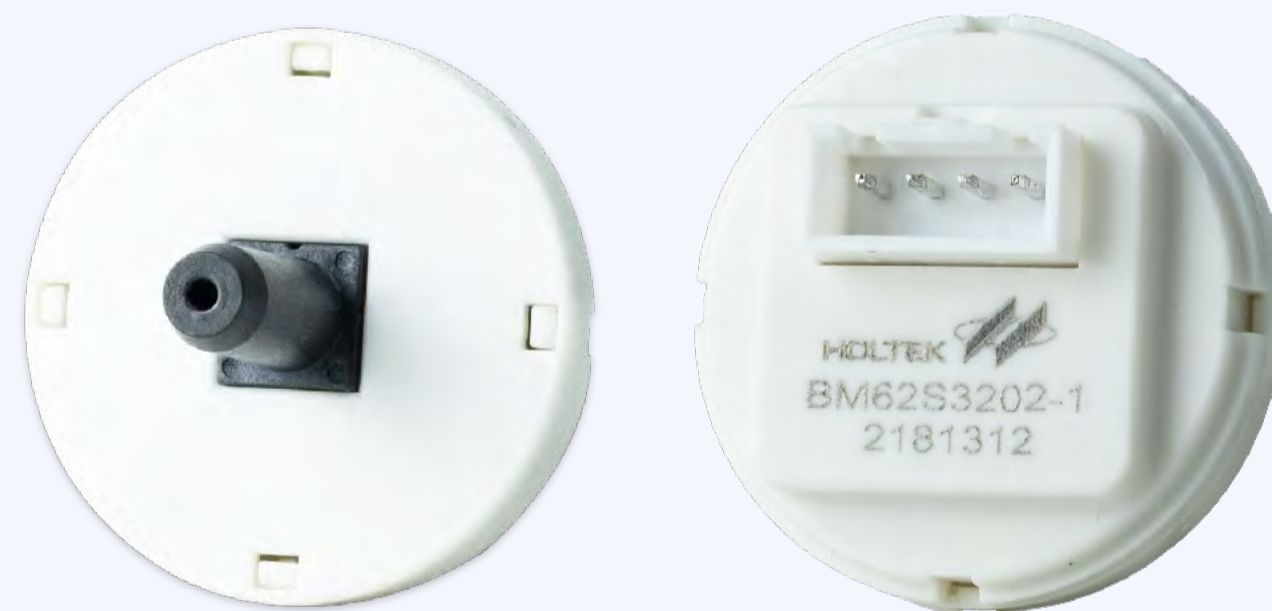
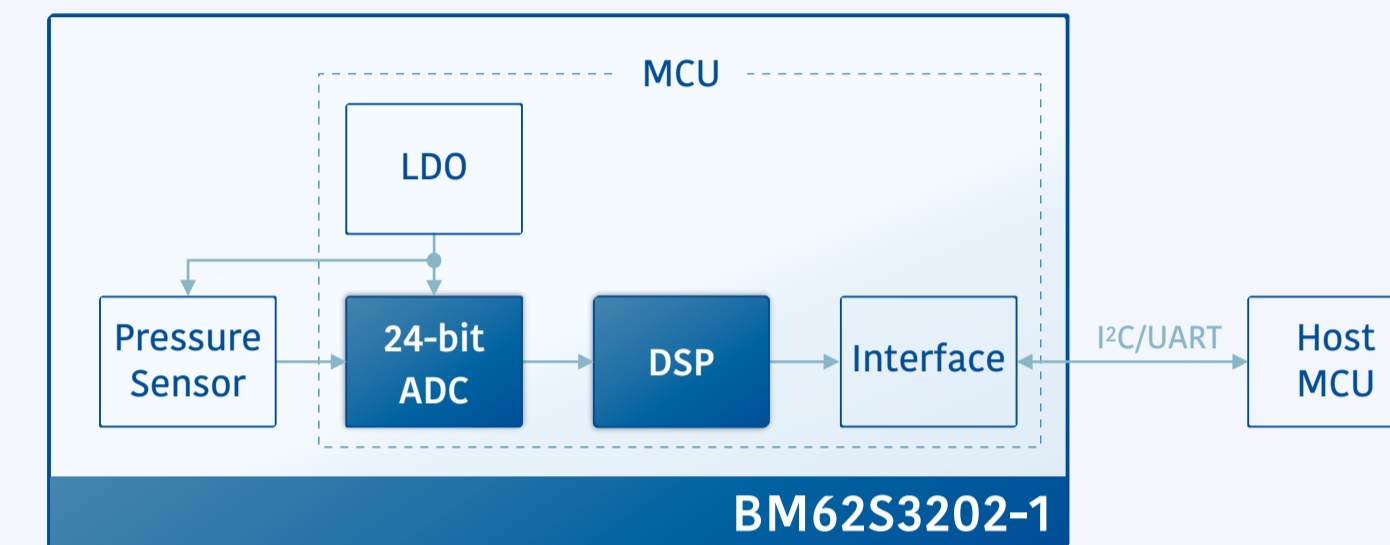

Applications

Washing machines, dehumidifiers, coffee machines, etc.

